

STH28

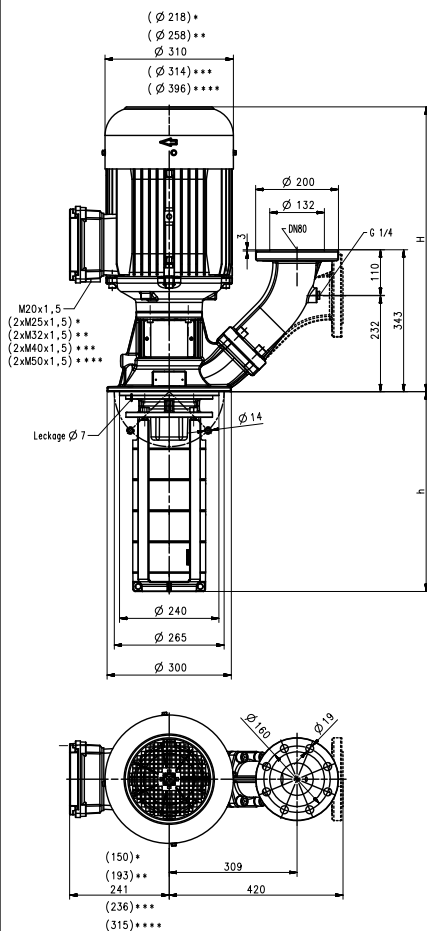

- *) Dimensions for 3 kW...6 kW
- **) Dimensions for 7.5 kW...10.3 kW
- *) Dimensions for 11 kW
- ***) Dimensions for 15 kW...25.3 kW
- ****) Dimensions up to 30 kW

Type	Vol. del. at manom. del. head l/min / m	Height H mm	Depth of immersion h mm	Weight kg	Power kW	Voltage 3 ~ V	Fre- quen- cy Hz	Current A	Speed 1/min
STH2801-1A280	1200/13	601	272	89	5.0	220-240 380-415	50 50	17.3 10.0	2920 2920
STH2801-0A280	1200/18	601	272	89	5.5	220-240 380-415	50 50	18.9 10.9	2915 2915
STH2802-2A370	1200/28	680	362	129	9.0	380-415	50	16.7	2955
STH2802-0A370	1200/39	688	362	151	11.0	380-415	50	20.1	2960
STH2803-2A460	1200/50	982	452	171	15.0	400	50	27	2960
STH2803-0A460	1200/61	1042	452	181	18.5	400	50	32	2955
STH2804_2A550	1200/73	1046	542	195	22.0	400	50	37.5	2950
STH2804-0A550	1200/83								
STH2805-2A640	1200/95	1125	632	305	30.0	400	50	53	2960
STH2805-0A640	1200/106								

Immersion Pumps

series STH use **closed impellers** in order to minimize power consumption and to optimize hydraulic pump efficiencies. The STH series offers high pressures at short immersion depths. A **frequency converter** can be supplied for **special applications** or for matching the pump characteristic to a specific duty point. See page "Control/Regulation" in the Technical Information section of this catalog for further information.

Extended lengths are available. See medium pressure pumps features within the technical information section.

Applications

Types of fluid
 coolants
 cooling/cutting oils
 Kinematic viscosity
 ...45 mm²/s (45 cSt)
 Pumping temperature
 0...90° C

Construction

Pump body	cast iron
Cover	cast iron
Impellers	CrNi-steel
Shaft	CrNi-steel
Diffusers	CrNi-steel
Mechanical seal	SiC
O-rings	Viton

Noise level (Motor only; Tolerance +3 dBA)

STH2801-1A...STH2801-0A	71 dBA
STH2802-2A...STH2802-0A	74 dBA
STH2803-2A...STH2805-0A	78 dBA

