

STH28

Closed impellers

60 Hz

STH28

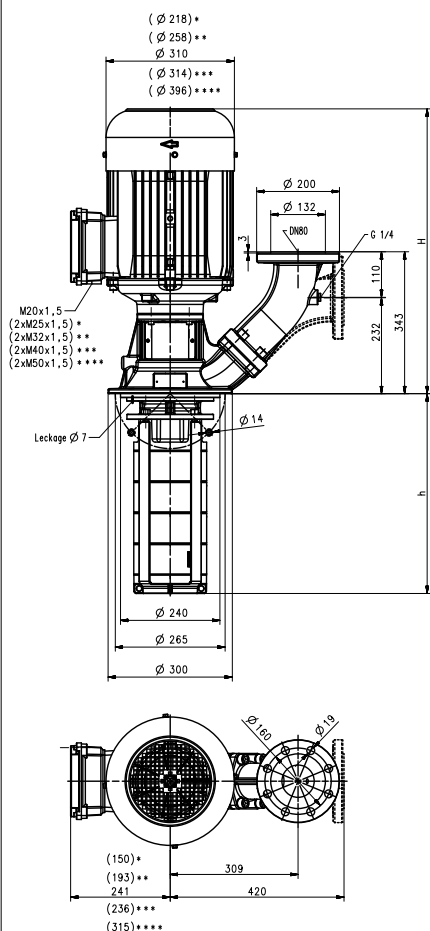

- *) Dimensions for 5.75 kW...6.9 kW
- **) Dimensions for 8.6 kW...10.3 kW
- Dimensions for 12.6 kW
- ***) Dimensions for 15 kW...25.3 kW
- ****) Dimensions up 33.5 kW

Type	Vol. del. at manom. del. head l/min /m	Height H mm	Depth of immersion h mm	Weight kg	Power kW	Voltage 3~ V	Fre- quen- cy Hz	Current A	Speed 1/min
STH2801-1B280	1300/22	642	272	112	7.48	460	60	11.5	3545
STH2801-0B280	1300/29	680	272	125	10.3	460	60	15.8	3550
STH2802-2B370	1300/47	688	362	150	15.0	460	60	23.6	3560
STH2802-0B370	1300/61	1042	362	177	21.3	460	60	32	3555
STH2803-2B460	1300/80	1046	452	192	25.3	460	60	37.5	3550
STH2803-0B460	1300/95	1125	452	298	33.5	460	60	52	3555

Immersion Pumps

series STH use **closed impellers** in order to minimize power consumption and to optimize hydraulic pump efficiencies. The STH series offers high pressures at short immersion depths. A **frequency converter** can be supplied for **special applications** or for matching the pump characteristic to a specific duty point. See page "Control/Regulation" in the Technical Information section of this catalog for further information.

Extended lengths are available. See medium pressure pumps features within the technical information section.

Applications

- Types of fluid
 - coolants
 - cooling/cutting oils
- Kinematic viscosity
 - ...45 mm²/s (45 cSt)
- Pumping temperature
 - 0...90° C

Construction

Pump body	cast iron
Cover	cast iron
Impellers	CrNi-steel
Shaft	CrNi-steel
Diffusers	CrNi-steel
Mechanical seal	SiC
O-rings	Viton

Noise level (Motor only; Tolerance +3 dBA)

STH2801-1B...STH2801-0B	77 dBA
STH2802-2B	79 dBA
STH2802-0B...STH2803-0B	81 dBA

